

# Tre Modular - Liminal Space

## DIY Assembly Guide v1.2

Thank you for choosing Tre Modular.

In this guide, we will walk you through the process of assembling your very own Tre Modular - Liminal Space module.

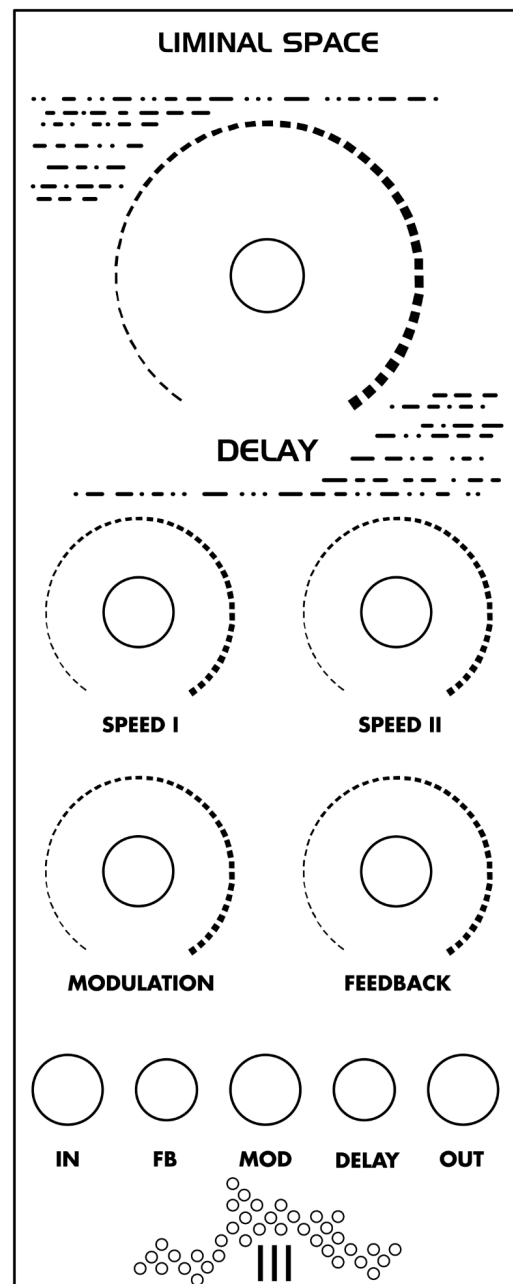

## Before You Begin:

This guide assumes a basic soldering proficiency, so if you're new to the craft, consider practicing on a spare PCB to build confidence.

Always adhere to proper soldering techniques, work in a well-ventilated space, and handle electronic components with care to ensure the longevity and optimal performance of your Liminal Space.

Ensure you have all the necessary components listed in the Bill of Materials. Familiarize yourself with the provided component list, and if any questions arise, don't hesitate to ask at [support@tremodular.com](mailto:support@tremodular.com).

## BOM (Bill of materials):

### Capacitors:

100p (101) - x2  
1n (Film) - x2  
2n2 (Film) - x2  
10n (103) - x4  
22n (Film) - x1  
33n (Film) - x3  
47n (Film) - x1  
100n (104) - x8  
100n (Film)(.1J) - x2  
1uf (Electrolytic) - x3  
10uf (Electrolytic) - x6

### Diodes:

1N4148 - x3  
1N5819 - x2

### Resistors:

680r - x2  
1K - x4  
2K - x3  
10K - x14  
15K - x1  
20K - x3  
39K - x1

47K - x1  
75K - x2  
100K - x6  
1M5 - x1

### Transistors:

2N3904 - x1  
LM78L05 - x1

### Buttons:

Button (momentary) - x2

### Potentiometers:

B100K - x5

### Connectors:

IDC-2.54-2X5P - x1

### Jack sockets:

Mono Switched x3

# Legend:

Front:

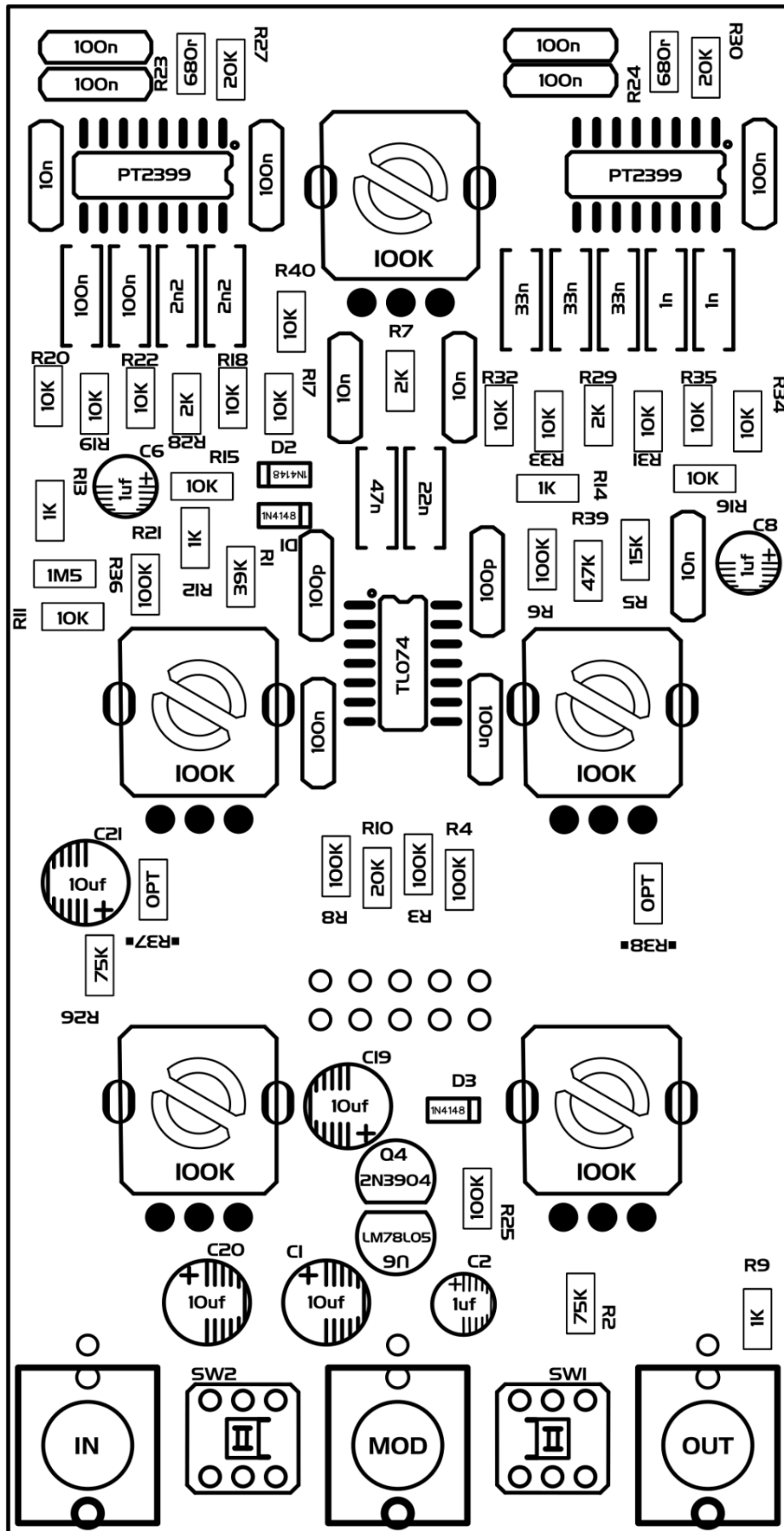

\*OPT\* - Optional

\*\*Buttons must be placed in specific orientation. See "Button orientation" section under step 9.

Back:

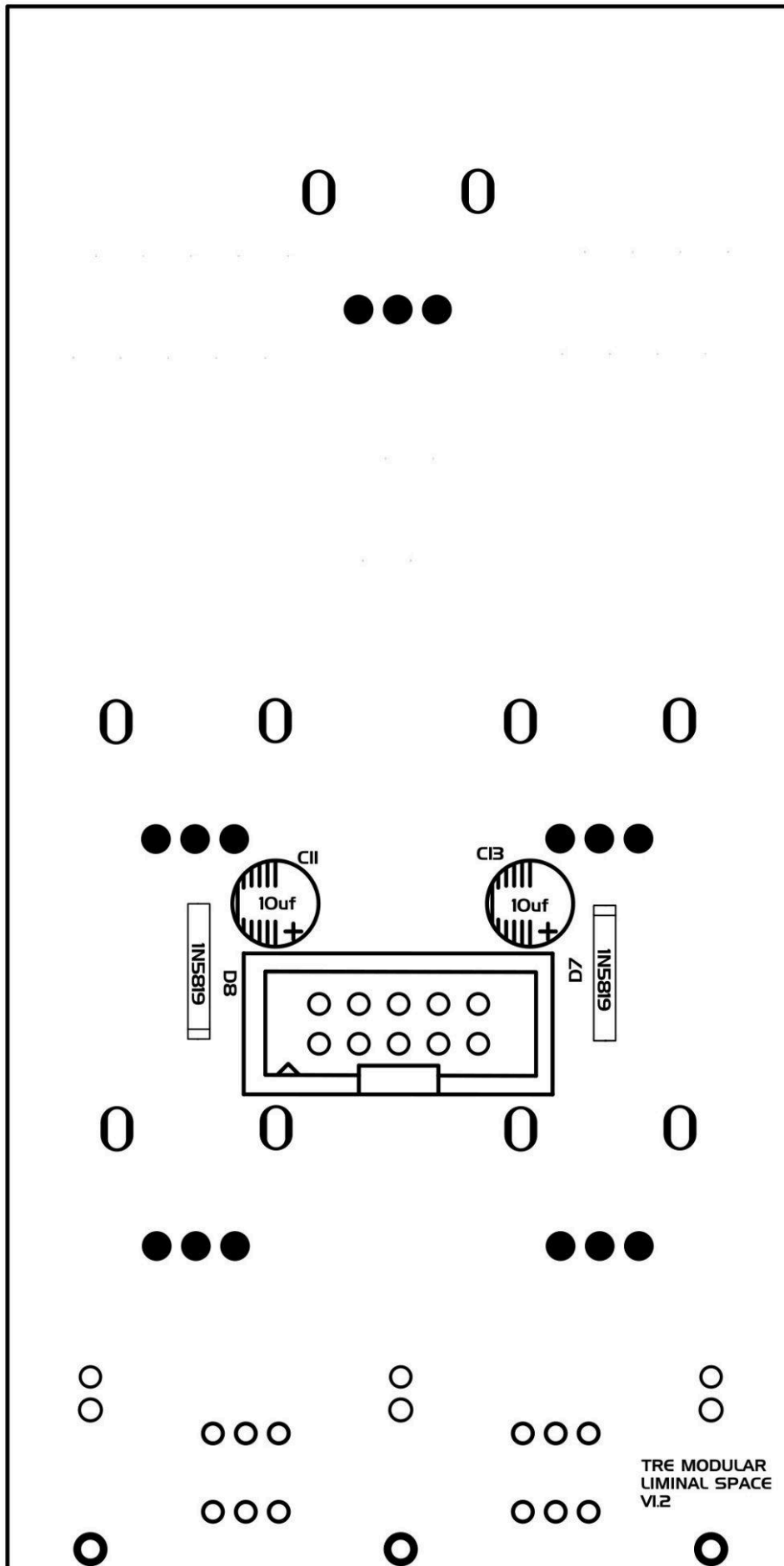

## Modifications:

If PT2399 delay times are pushed beyond 1sec they get progressively more glitchy and distorted. For those of you who want to embrace glitchiness of PT2399 you can replace 100K speed potentiometers with higher value ones. We have also included two optional resistor pads - R37 and R38. They are for limiting resistors. With the help of them you can limit delay times to a specific amount. They are useful because with higher value potentiometers you get wider range but less resolution in dialing in specific amounts of delay speed. With limiting resistors you can limit delay times to the amount you specifically want.

To calculate the approximate delay time (**DT**) that you will get with different resistor and potentiometer combos, you can use this formula:

$$DT = (11.46 \times Rt) + 29$$

To determine the total resistance (**Rt**) from a potentiometer resistance (**Rpot**) and a limiting resistor resistance (**R**), use:

$$Rt = \frac{(Rpot \times R)}{(Rpot + R)}$$

Or if you want to get specific delay speeds you can use this formula instead to calculate the necessary resistance:

$$Rt = \frac{(DT - 29)}{11.46}$$

Once you determine total resistance (**Rt**), you can calculate limiting resistor(**R**) by replacing **Rpot** with your chosen potentiometer resistance value :

$$R = \frac{Rt \times Rpot}{Rpot - Rt}$$

**DT** - Delay time (ms)

**11.46** - rate at which delay increases per kΩ

**29** - this is the base delay when the resistor is close to zero.

**Rt** - Total resistance (kΩ).

**Rpot** - Potentiometer resistance (kΩ).

**R** - Limiting resistor resistance (kΩ).

R37 and R38 can also be used if you simply want to limit the range of delay to avoid delay speeds that introduce noise. For example you could use 39K resistor as a limiting resistor with 100K potentiometer and you would limit the delay to around 350ms. This would avoid any noise and give more resolution in dialing in specific delay speed.

When ordering you can ask and we will replace 100K speed resistors with 1M resistors and help you understand how to achieve what you want. Just contact us at [support@tremodular.com](mailto:support@tremodular.com) .

## Assembly Guide:

### Step 1: Identify and Sort Components

Organize the components into groups based on their types: resistors, capacitors, transistors, diodes, potentiometers, connectors, switches and jack sockets.

### Step 2: Transistors

Place and solder 2N3904 transistor in its designated location.

Place and solder LM78L05 voltage regulator in its designated location.

### Step 3: Diodes (Front)

Insert and solder 1N4148 diodes according to the legend.

1N4148 diodes are placed vertically.

Body of the 1N4148 diode should rest on the triangle part of the diode symbol.

Ensure correct orientation, referring to the diode's polarity.

For easier soldering, when 1N4148 diode is placed on the PCB, bend the leg closest to the diode's body to keep it in place, and then solder the other leg. Once this is done, straighten the bent leg and proceed with soldering it in place.

#### **Step 4: Capacitors**

Start with soldering ceramic capacitors onto their designated positions on the PCB according to legend.

Soldering 10Uf(x4) electrolytic capacitors onto the designated positions on the PCB according to legend.

Solder 1Uf capacitors onto the designated positions on the PCB according to legend.

Ensure the electrolytic capacitors are oriented correctly, paying attention to their polarity.

Solder film capacitors onto their designated positions on the PCB according to legend.

#### **Step 5: Resistors**

Resistors are placed vertically.

Refer to the legend for resistor placement.

Start with the lowest resistance value and continue soldering resistors in ascending order, referring to the BOM and legend for values and placement.

For easier soldering, when a resistor is placed on the PCB, bend the leg closest to the resistor's body to keep it in place, and then solder the other leg. Once this is done, straighten the bent leg and proceed with soldering it in place.

#### **Step 6: Diodes (Back)**

Insert and solder 1N5819 diodes according to the legend.

Ensure correct orientation, referring to the diode's polarity.

#### **Step 7: Capacitors (Back)**

Solder 10Uf capacitors onto the designated positions on the PCB according to legend.

Ensure the capacitor is oriented correctly, paying attention to its polarity.

### Step 8: Power Connector (Back)

Solder the IDC connector (Power connector) into its designated spot. Start by soldering one pin and reflow the solder if the connector is not aligned. If everything is aligned, proceed to soldering the rest of the pins.

### Step 9: Potentiometers, Jack Sockets and buttons.

Insert all potentiometers, Jack sockets and buttons into their positions on the PCB.

Pay attention to orientation of buttons. Notch in the button's shaft indicates the orientation of the button according to legend.

Put on the front panel and fasten it. Ensure everything is aligned properly and then solder everything in place.

#### Button orientation:

Look for a notch on the button's shaft marked in this picture. ->

This notch should be oriented facing notch symbol on the

legend marked in this picture.->

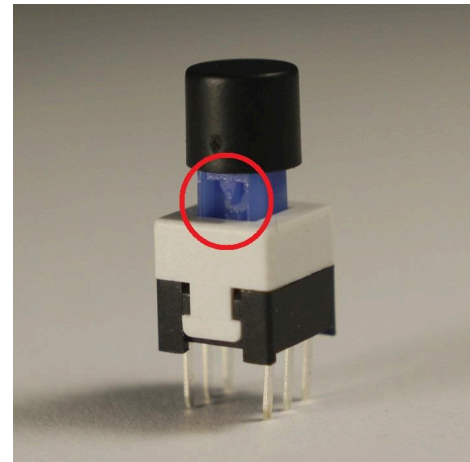
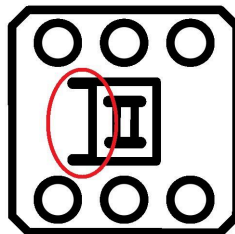

### Step 10: Final Inspection

Double-check your work against the BOM and legend.

Visually inspect your solder joints for bridges or cold joints.

Ensure all components are securely attached to the PCB.



## Step 11: Installation

Power off your Eurorack system.

Connect the power cable, ensuring correct polarity.

Power on your Eurorack system.

If the module is working as it should. Insert the module into an available slot in your rack and secure it in place.

Enjoy!

## Additional Information:

For any additional questions or support, please contact Tre Modular at [support@tremodular.com](mailto:support@tremodular.com) .

Happy patching!

