

Tre Modular - Shape Mod

DIY Assembly Guide v3.0

Thank you for choosing Tre Modular!

In this guide, we will walk you through the process of assembling your very own Tre Modular - Shape Mod module.

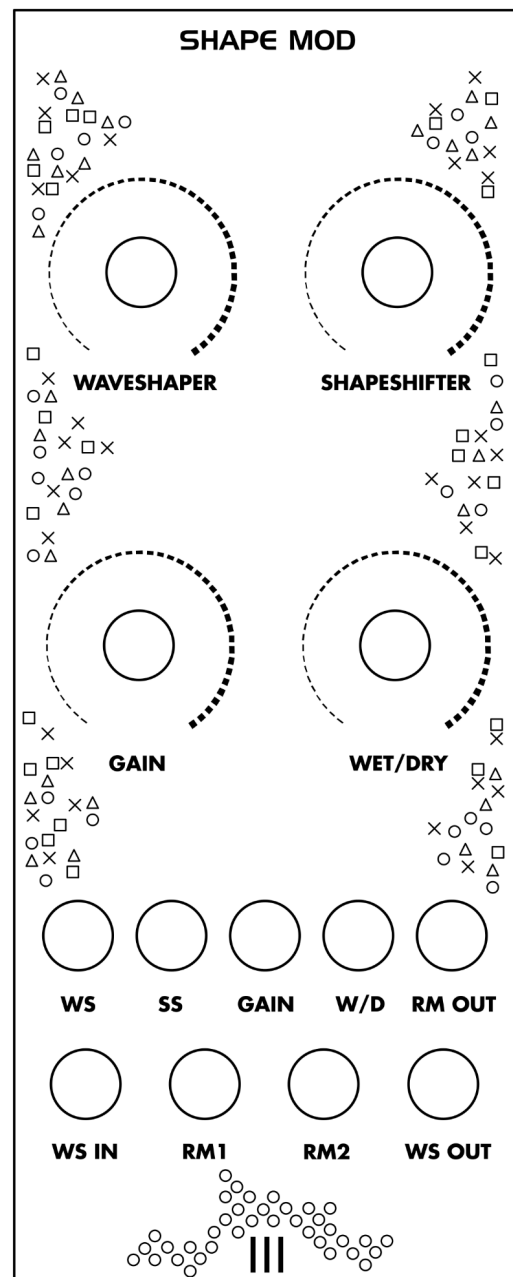

Before You Begin:

This guide assumes a basic soldering proficiency, so if you're new to the craft, consider practicing on a spare PCB to build confidence.

Always adhere to proper soldering techniques, work in a well-ventilated space, and handle electronic components with care to ensure the longevity and optimal performance of your Shape Mod.

Ensure you have all the necessary components listed in the Bill of Materials. Familiarize yourself with the provided component list, and if any questions arise, don't hesitate to ask at support@tremodular.com.

BOM (Bill of materials):

Resistors:

220r - x1
680r - x1
820r - x3
1K - x13
2K2 - x1
3K3 - x1
6K8 - x3
10K - x8
12K - x1
15K - x7
22K - x3
27K - x6
39K - x2
47K - x6
51K - x3
68K - x2
75K - x2
100K - x6
150K - x2
270K - x1

Capacitors:

10uf 50v - x2
100n (104) - x10

Diodes:

1N4148 - x8
1N5819 - x2

Transistors:

2N3904 - x2

Switches:

Mini slide switch - x1

Connectors:

IDC-2.54-2X5P - x1

Potentiometers:

B100K - x4

Jack sockets:

Mono Switched x9

Legend:

Front:

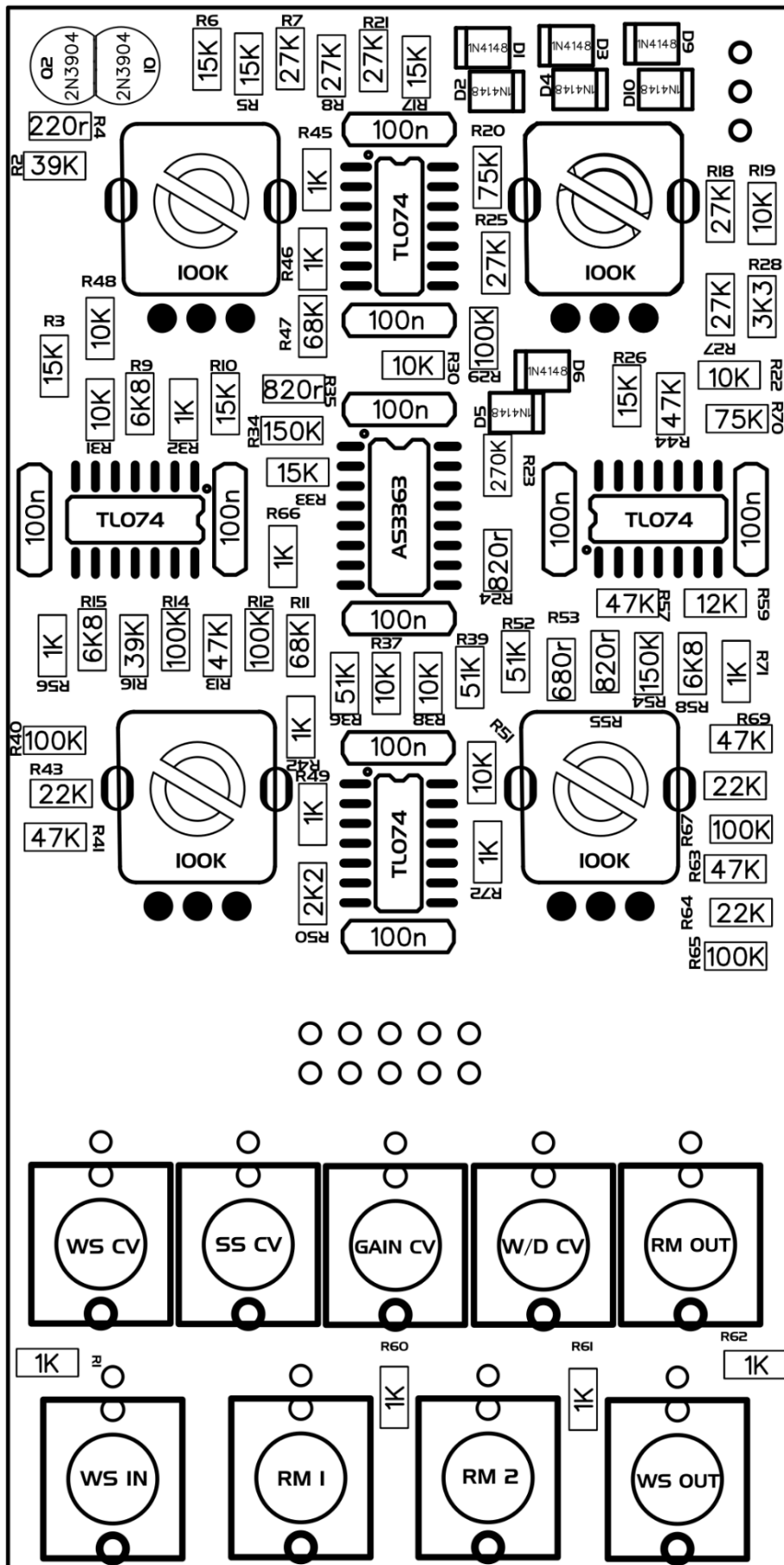

Back:

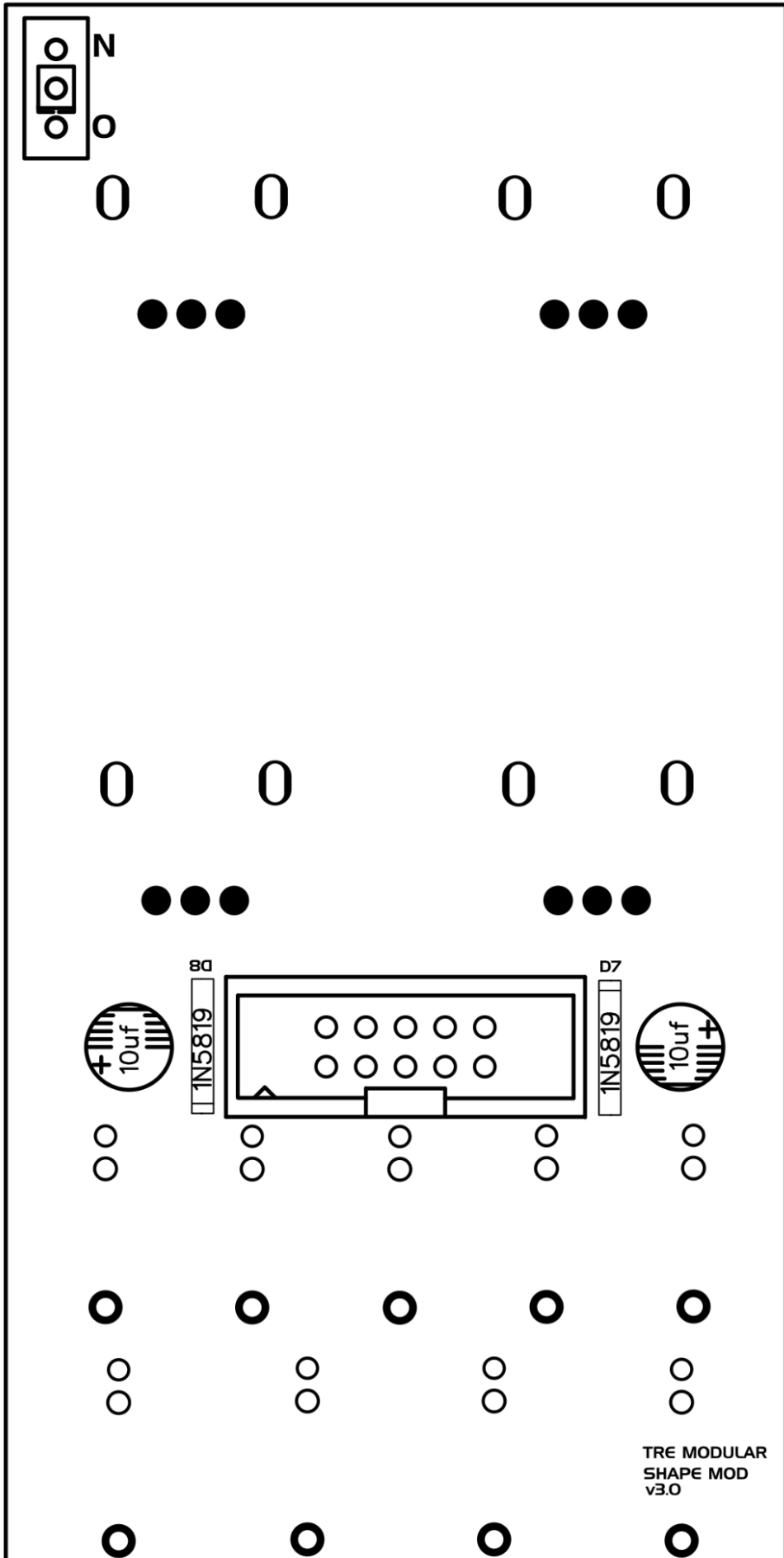

Assembly Guide:

Step 1: Identify and Sort Components

Organize the components into groups based on their types: resistors, capacitors, diodes, transistors, potentiometers, connectors, and jack sockets.

Step 2: Transistors

Place and solder the 2N3904 transistors in their designated locations.

Step 3: Diodes (Front)

Insert and solder 1N4148 diodes according to the legend.

1N4148 diodes are placed vertically.

For easier soldering, when 1N4148 diode is placed on the PCB, bend the leg closest to the diode's body to keep it in place, and then solder the other leg. Once this is done, straighten the bent leg and proceed with soldering it in place.

Step 4: 100n Capacitors

Solder 100n capacitors onto the designated positions on the PCB according to legend..

Step 5: Resistors

Resistors are placed vertically.

Refer to the legend for resistor placement.

Start with the lowest resistance value and continue soldering resistors in ascending order, referring to the BOM and legend for values and placement.

For easier soldering, when a resistor is placed on the PCB, bend the leg closest to the resistor's body to keep it in place, and then solder the other leg. Once this is done, straighten the bent leg and proceed with soldering it in place.

Step 6: Diodes (Back)

Insert and solder 1N5819 diodes according to the legend.

Ensure correct orientation, referring to the diode's polarity.

Step 7: Capacitors (Back)

Solder 10uf capacitors onto the designated positions on the PCB according to legend.

Ensure correct orientation of 10uf electrolytic capacitors, referring to the capacitors polarity.

Step 8: Slide Switch

Insert and solder the slide switch into its designated positions on the PCB.

Step 9: Connectors

Solder the IDC connector (Power connector) into its designated spot. Start by soldering one pin and reflow the solder if the connector is not aligned. If everything is aligned, proceed to soldering the rest of the pins.

Step 10: Potentiometers and Jack Sockets

Insert all potentiometers and Jack sockets into their positions on the PCB. Put on the front panel and fasten it. Ensure they align properly and then solder everything in place.

Step 11: Final Inspection

Double-check your work against the BOM and legend.

Visually inspect your solder joints for bridges or cold joints.

Ensure all components are securely attached to the PCB.

Step 12: Installation

Power off your Eurorack system.

Insert the module into an available slot.

Connect the power cable, ensuring correct polarity.

Power on your Eurorack system.

Enjoy!

Additional Information:

For any additional questions or support, please contact Tre Modular at support@tremodular.com.

Happy patching!

