

Tre Modular - Alisa VCO

DIY Assembly Guide v2.2

Thank you for choosing Tre Modular.

In this guide, we will walk you through the process of assembling your very own Tre Modular - Alisa VCO module.

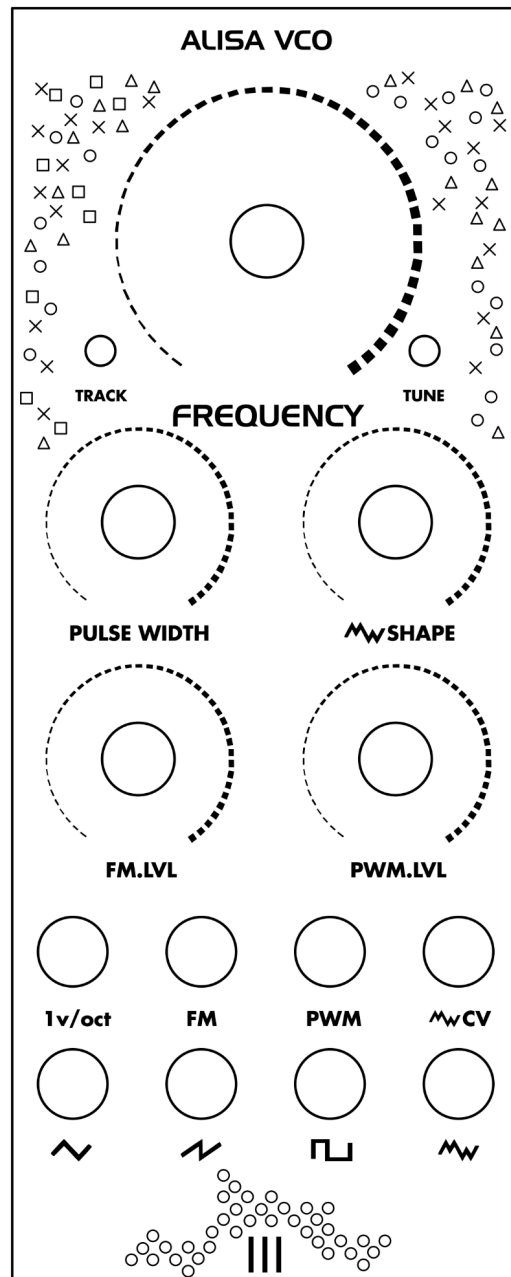

Before You Begin:

This is an advanced build, so if you're new to the craft, consider buying a pre-assembled module instead or seek help from somebody who has experience in complex builds.

Always adhere to proper soldering techniques, work in a well-ventilated space, and handle electronic components with care to ensure the longevity and optimal performance of your Alisa VCO.

Ensure you have all the necessary components listed in the Bill of Materials. Familiarize yourself with the provided component list, and if any questions arise, don't hesitate to ask at support@tremodular.com.

BOM (Bill of materials):

Capacitors:

100p(101) x2
1.5nF(Film) x1
100n(104) x12
10uf 50v x2
22n(Film) x1

Resistors:

220r x2
390r x1
1K x2
2K x2
2K2 x3
3K3 x1
3K9 x2
4K7 x2
6K8 x1
10K x10
15K x7
20K x2
22K x1
27K x11
30K x1
39K x1
47K x2
68K x2

75K x2

100K x9

150K x1

1M x1

Diodes:

"1N4148 x10"

"1N4002 x2"

Transistors:

2N3904 x2

J201 x1

Potentiometers:

B100K x5

100K(104) Trimpot x3

100r(101) Trimpot x1

Connectors:

IDC-2.54-2X5P - x1

Jack sockets:

Mono Switched x8

Legend:

Front:

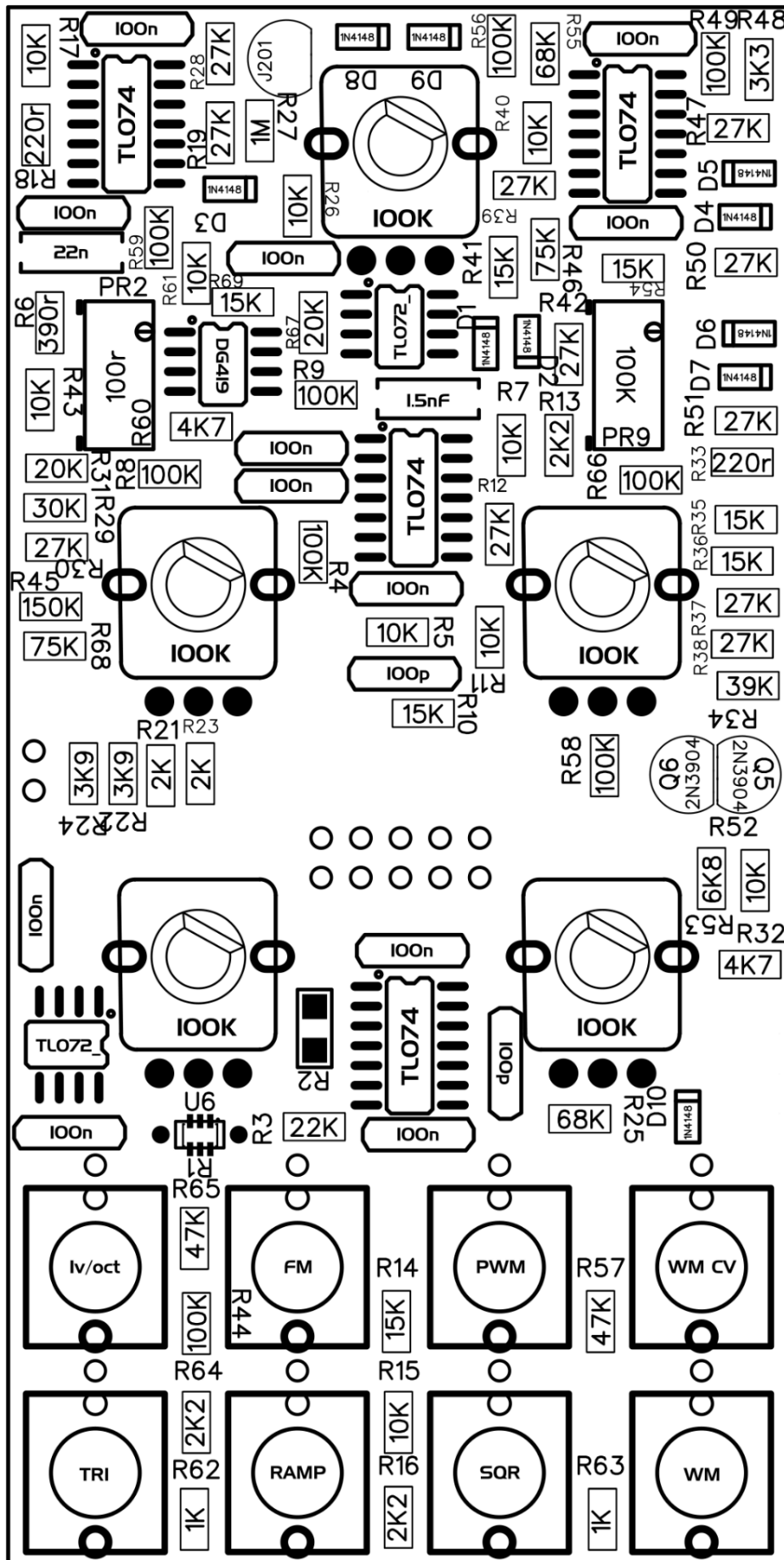

Back:

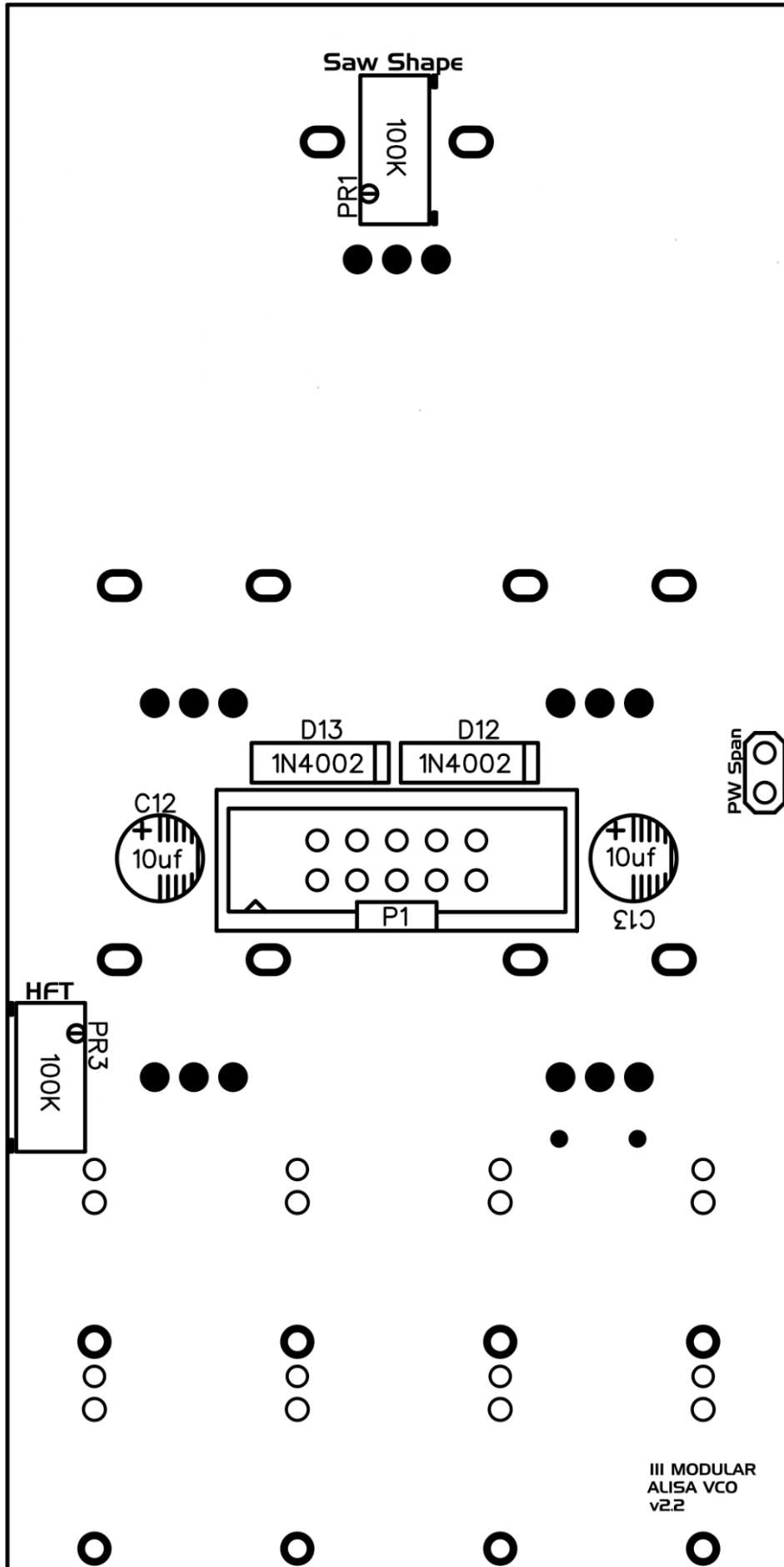

III MODULAR
ALISA VCO
v2.2

Assembly Guide:

Step 1: Identify and Sort Components

Organize the components into groups based on their types: resistors, capacitors, diodes, potentiometers, connectors, switches and jack sockets.

Step 2: Diodes (Front)

Insert and solder 1N4148 diodes according to the legend.

1N4148 diodes are placed vertically.

For easier soldering, when 1N4148 diode is placed on the PCB, bend the leg closest to the diode's body to keep it in place, and then solder the other leg. Once this is done, straighten the bent leg and proceed with soldering it in place.

Step 3: Transistors

Place and solder all transistors in its designated location.

Step 4: Capacitors (Front)

Solder all capacitors onto the designated positions on the PCB according to legend.

Start with physically smaller capacitors.

Step 5: Resistors

Resistors are placed vertically.

Refer to the legend for resistor placement.

Start with the lowest resistance value and continue soldering resistors in ascending order, referring to the BOM and legend for values and placement.

There are two 10k resistors that are separate from others and marked as R5 and R7. These are matched resistors that should be used in their corresponding placement according to legend.

For easier soldering, when a resistor is placed on the PCB, bend the leg closest to the resistor's body to keep it in place, and then solder the other leg. Once this is done, straighten the bent leg and proceed with soldering it in place.

Step 6: Diodes (Back)

Insert and solder 1N4002 diodes according to the legend.

Ensure correct orientation, referring to the diode's polarity.

Step 7: 10uf Capacitors (Back)

Solder 10uf capacitors onto the designated positions on the PCB according to legend.

Ensure correct orientation of capacitors, referring to the capacitors polarity.

Step 8: Power Connector

Solder the IDC connector (Power connector) into its designated spot. Start by soldering one pin and reflow the solder if the connector is not aligned. If everything is aligned, proceed to soldering the rest of the pins.

Step 9: Trimpots (Back)

Solder the Trimpots into their designated spots. Start by soldering one pin and reflow the solder if it is not aligned. If everything is aligned, proceed to soldering the rest of the pins.

Step 10: Potentiometers, trimpots(front) and Jack Sockets

Insert all potentiometers, trimpots and jack sockets into their positions on the PCB.

Put on the front panel and fasten it. Ensure everything is aligned properly and then solder everything in place.

Step 11: Final Inspection

Double-check your work against the BOM and legend.

Visually inspect your solder joints for bridges or cold joints.

Ensure all components are securely attached to the PCB.

Step 12: Calibration.

Power off your Eurorack system.

Connect the power cable, ensuring correct polarity.

Power on your Eurorack system.

Let the module warm up for at least 20 minutes.

Turn the frequency knob all the way counter clockwise.

Turn the HFT trimpot counter clockwise until you hear clicking from the trimpot.

Connect a tuner to the triangle output of the VCO.

Connect a 1V/oct keyboard to 1V/oct input.

Play C4 on the keyboard and adjust TUNE trimpot so that the tuner shows C4.

Play C5 on the keyboard and adjust TRACK trimpot so that the tuner shows C5.

Play C4 again on the keyboard and adjust TUNE trimpot so that the tuner shows C4.

You will have to go back and forth until the tuner shows C4 and C5 when you play them on the keyboard.

Once C4 and C5 are tuned you can check C3, C6 and C7 in a similar manner as you did with C4 and C5 and adjust if necessary.

HFT trimpot is used to tune higher frequency notes if necessary. Be aware that it will affect tracking on lower notes as well when adjusted. So expect to go back and forth between HFT and TRACK trimpot when adjusting it.

If the module is working as it should. Insert the module into an available slot in your rack and secure it in place.

Enjoy!

Additional Information:

For any additional questions or support, please contact Tre Modular at support@tremodular.com .

Happy patching!

