

Tre Modular - Quad LFO

DIY Assembly Guide

Thank you for choosing Tre Modular!

In this guide, we will walk you through the process of assembling your very own Tre Modular - Quad LFO module.

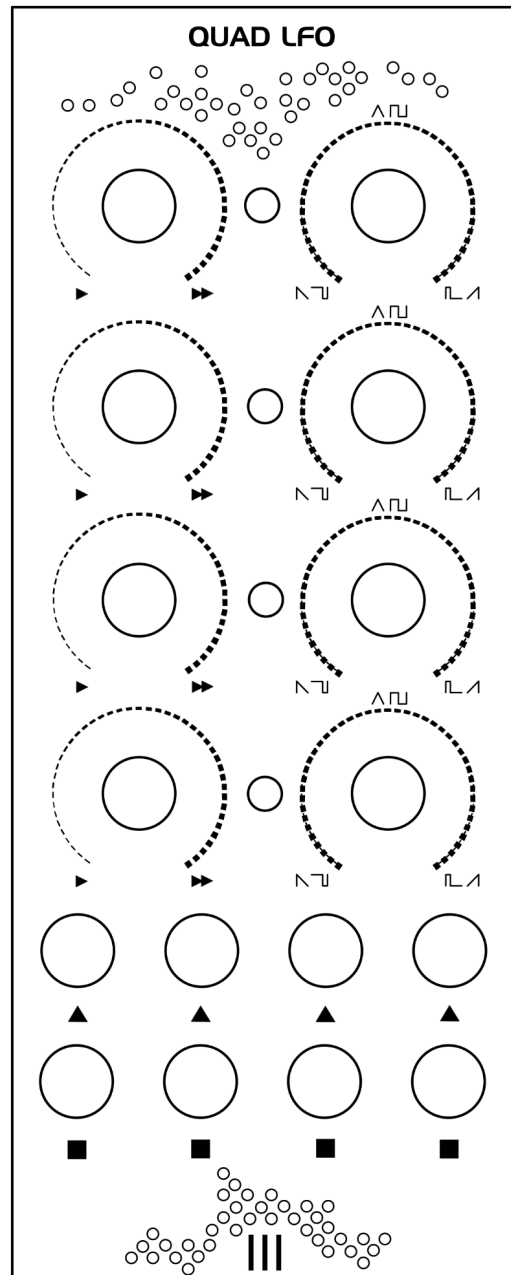

Before You Begin:

This guide assumes a basic soldering proficiency, so if you're new to the craft, consider practicing on a spare PCB to build confidence.

Always adhere to proper soldering techniques, work in a well-ventilated space, and handle electronic components with care to ensure the longevity and optimal performance of your Quad LFO.

Ensure you have all the necessary components listed in the Bill of Materials. Familiarize yourself with the provided component list, and if any questions arise, don't hesitate to ask at support@tremodular.com

BOM (Bill of materials):

Capacitors:

10uf(Electrolytic) - x2

22n(Film) - x4

100n(Ceramic) - x4

3K3 - x4

3K9 - x4

75K - x4

150K - x4

270K - x4

Diodes:

1N4148 - x8

1N4002 - x2

LED - x4

Potentiometers:

B100K - x4

B1M -x4

Resistors:

470r - x4

1K - x12

2K2 - x4

Connectors:

IDC - 2X5 Pin - x1

Jack sockets:

Mono Switched x8

Legend:

Front:

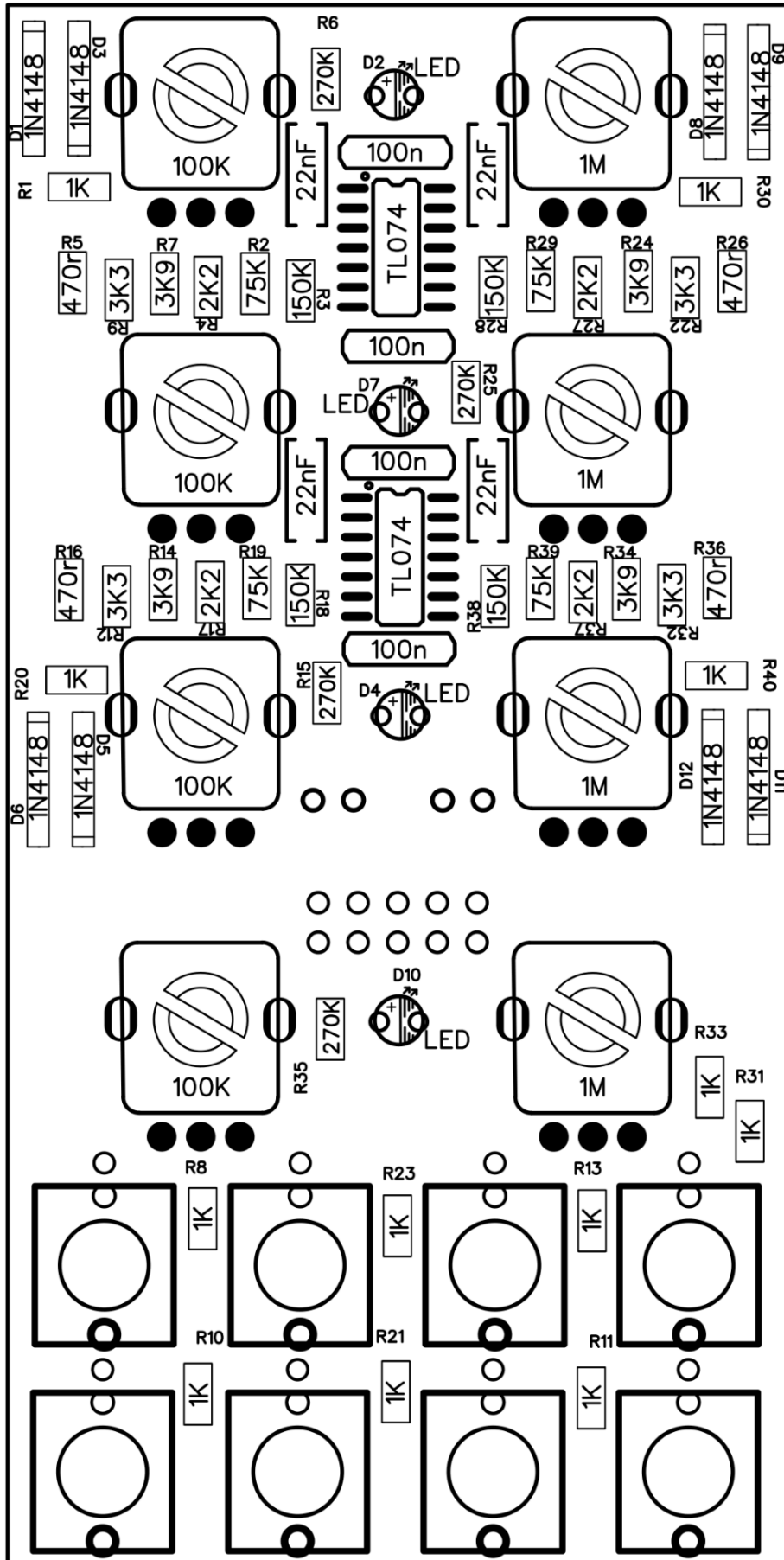

Back:

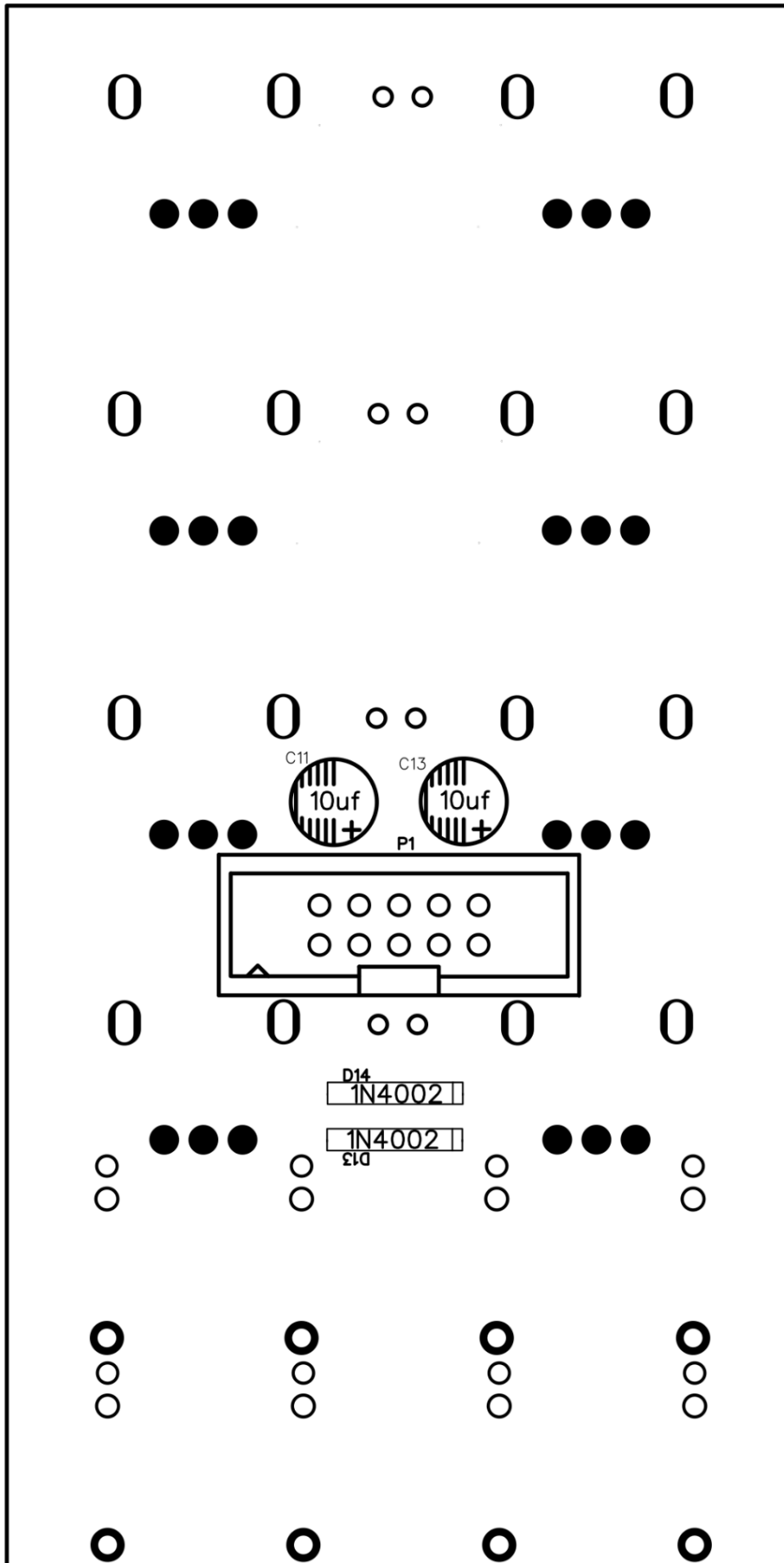

Assembly Guide:

Step 1: Identify and Sort Components

Organize the components into groups based on their types: resistors, capacitors, diodes, potentiometers, connectors, and jack sockets.

Step 2: Diodes (Front)

Insert and solder 1N4148 diodes according to the legend.

Ensure correct orientation, referring to the diode's polarity.

Step 3: Capacitors (Front)

Solder the capacitors onto the designated positions on the PCB according to legend.

Step 4: Resistors

Resistors are placed vertically.

Refer to the legend for resistor placement.

Start with the lowest resistance value and continue soldering resistors in ascending order, referring to the BOM and legend for values and placement.

For easier soldering, when a resistor is placed on the PCB, bend the leg closest to the resistor's body to keep it in place, and then solder the other leg. Once this is done, straighten the bent leg and proceed with soldering it in place.

Step 5: Diodes (Back)

Insert and solder 1N4002 diodes according to the legend.

Ensure correct orientation, referring to the diode's polarity.

Step 6: Capacitors (Back)

Solder 10uf capacitors onto the designated positions on the PCB according to legend.

Ensure correct orientation of electrolytic capacitors, referring to the capacitors polarity.

Step 7: Connectors

Solder the IDC connector (Power connector) into its designated spot. Start by soldering one pin and reflow the solder if the connector is not aligned. If everything is aligned, proceed to soldering the rest of the pins.

Step 8: Potentiometers, LED`s and Jack Sockets

Insert all potentiometers, LED`s and Jack sockets into their positions on the PCB. Put the front panel on and fasten it. Ensure that everything aligns properly and then solder everything in place.

Ensure correct orientation of LED`s. Usually the long lead goes to the positive pin.

Step 9: Final Inspection

Double-check your work against the BOM and legend.

Visually inspect your solder joints for bridges or cold joints.

Ensure all components are securely attached to the PCB.

Step 10: Installation

Power off your Eurorack system.

Insert the module into an available slot.

Connect the power cable, ensuring correct polarity.

Power on your Eurorack system.

Enjoy!

Additional Information:

For any additional questions or support, please contact Tre Modular at support@tremodular.com

Happy patching!

